

# DJI Smart Controller Enterprise

User Guide

使用说明

v1.0 2019.12

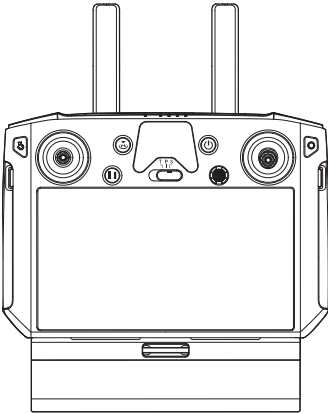

## Disclaimer

Please read this entire document and all safe and lawful practice DJI™ provided carefully, and visit the DJI official website (<http://www.dji.com>) to download the full version of the User Manual and carefully read all instructions and warnings therein before use. Failure to read and follow instructions and warnings or lack of strong awareness of safety during the operation may result in serious injury to yourself or others, damage to your DJI product, or damage to other objects in the vicinity. By using this product, you hereby signify that you have read this disclaimer and warning carefully and that you understand and agree to abide by the terms and conditions herein. You agree that you are solely responsible for your own conduct while using this product, and for any consequences thereof. DJI accepts no liability for damage, injury or any legal responsibility incurred directly or indirectly from the use of this product.

DJI is a trademark of SZ DJI TECHNOLOGY CO., LTD. (abbreviated as “DJI”) and its affiliated companies. Names of products, brands, etc., appearing in this document are trademarks or registered trademarks of their respective owner companies. This product and document are copyrighted by DJI with all rights reserved. No part of this product or document shall be reproduced in any form without the prior written consent or authorization of DJI.

This document and all other collateral documents are subject to change at the sole discretion of DJI. For up to date product information, visit <http://www.dji.com> and click on the product page for this product.

This disclaimer is available in various languages. In the event of divergence among different versions, the English version shall prevail.

## Warning

Always stay alert when using the DJI Smart Controller Enterprise (hereinafter referred as “Smart Controller”) to control an Unmanned Aerial Vehicle (UAV). Carelessness may result in serious harm to yourself and others. Always download and read the Disclaimer and Safety Guidelines of the aircraft and the detailed User Manual before usage.

1. Fully charge the Smart Controller before each flight.
2. If the Smart Controller is turned on and the touch screen is off for five minutes, an alert sound will be triggered. Ten seconds after the alert sound, the Smart Controller will automatically power off. Move the sticks or perform some other action to cancel the alert.
3. Ensure the antennas are unfolded and adjusted to the proper position to achieve the optimal transmission quality.
4. Contact DJI support to repair or replace the antennas if they are damaged. Damaged antennas will greatly decrease performance.
5. Link the Smart Controller and the aircraft again if you change the aircraft.
6. Ensure to power off the aircraft before the Smart Controller.
7. Fully charge the Smart Controller every three months.
8. Immediately charge the Smart Controller when its power level decreases to 10% to prevent the Smart Controller from damage due to over discharge for an extended period. Discharge the Smart Controller to a power level between 40% and 60% if stored for an extended period.
9. DO NOT cover the air vent on the Smart Controller. Otherwise, the Smart Controller may become too hot, which could affect its performance.
10. DO NOT disassemble the Smart Controller without the assistance of a DJI authorized dealer. Always contact Smart Controller's DJI or a DJI authorized dealer to replace the Smart Controller's components.
11. DO NOT block the Smart Controller's built-in GPS. In cases where the DJI Smart Controller Enterprise Screen Mounting Bracket (hereinafter referred as “Mounting Bracket”) is installed, remove it and try again if GPS signal is poor.
12. To avoid wear and tear of the Stick Covers, DO NOT disassemble the sticks on a frequent basis.

## Introduction

The DJI Smart Controller Enterprise (hereinafter referred to as "Smart Controller") features OCUSYNC™ Enterprise technology, capable of controlling aircraft that supports this technology, and providing a live HD view from the aircraft's camera. It can transmit image data at distances of up to 6.21 mi (10 km) and comes with a number of aircraft and gimbal controls as well as some customizable buttons. \*

The built-in 5.5-inch high brightness 1000 cd/m<sup>2</sup> screen has a resolution of 1920×1080 pixels, featuring an Android system with multiple functions such as Bluetooth and GNSS. In addition to supporting Wi-Fi connectivity, it is also compatible with other mobile devices for more flexible usage.

The Smart Controller has a maximum working time of 2.5 hours with the built-in battery. When using the WB37 Intelligent Battery, the maximum working time can be extended to 4.5 hours. \*\*

\* The Smart Controller can reach its maximum transmission distance (FCC) in an unobstructed area with no electromagnetic interference at an altitude of about 400 feet (120 meters). The actual maximum transmission distance may be less than the distance mentioned above due to interference in the operating environment, and the actual value will fluctuate according to the strength of interference. To comply with local regulations, the 5.8 GHz frequency is not available in some countries and regions.

\*\* Maximum run time is estimated in a lab environment, for reference only. When the Smart Controller is powering other devices, the run time will be diminished.

## In the Box

Smart Controller ×1

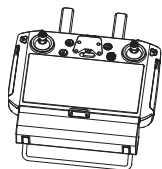

WB37 Intelligent Battery ×1

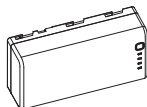

USB Charger \*\*\*

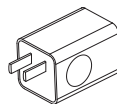

USB-C Cable ×1



USB Cable (with Double A Ports) ×1



Smart Controller Lanyard ×1



Spare Control Stick (pair) ×1



Spare Stick Cover (pair) ×1



Manuals



DJI Smart Controller Enterprise User Guide  
WB37 Intelligent Battery Safety Guidelines

\*\*\* The charger type varies depending on the region.

## Overview

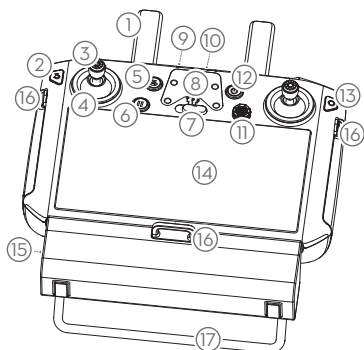

1. Antennas
2. Back Button / Function Button
3. Control Sticks
4. Stick Covers
5. RTH Button
6. Flight Pause Button
7. Flight Mode Switch
8. Position for Mounting Bracket (with built-in GPS module under it)
9. Status LED
10. Battery Level LEDs
11. 5D Button
12. Power Button
13. Confirm Button / Customizable Button C3
14. Touch Screen
15. Charging Port (USB-C)
16. Lanyard Hooks
17. Handle

18. Gimbal Pitch Control Dial
19. Record Button
20. HDMI Port
21. microSD Card Slot
22. USB-A Port
23. Focus / Shutter Button
24. Gimbal Pan Control Dial

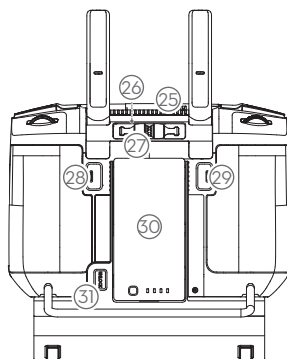
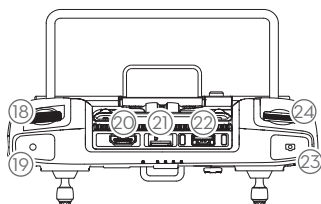

25. Air Vent
26. Sticks Storage Slot
27. Spare Sticks
28. Customizable Button C2
29. Customizable Button C1
30. WB37 Intelligent Battery
31. Battery Release Button

## 1. Charging the Smart Controller

It takes roughly 2 hours and 15 minutes to fully charge the Smart Controller using the standard USB charger.

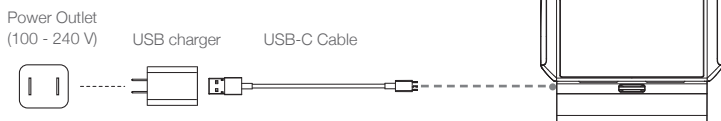

- ⚠ Please use the official USB charger to charge the Smart Controller. When a standard USB charger is not available, it is recommended to use an FCC / CE certified USB charger rated 12 V / 2 A.
- Please recharge the battery at least every three months to prevent over discharging - the battery will deplete when stored for an extended period.

## 2. Mounting the WB37 Intelligent Battery

- ① Press and hold the battery release button.
- ② Insert the Intelligent Battery into the battery compartment. Make sure the bottom of the battery is aligned to the marking line in the compartment.
- ③ Push the battery to the bottom.

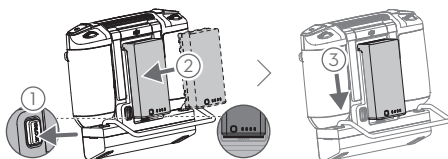

- 💡 To remove the Intelligent Battery, press and hold the battery release button, then push the battery upward.
- Refer to the BS60 Intelligent Battery Station User Guide for Intelligent Battery charging details.

## 3. Checking the Battery Level and Turning On

Check the internal battery level according to the Battery Level LEDs. Press the power button once to check it while turned off.

Press the power button once, press again and hold for a few seconds to turn on/off the Smart Controller.

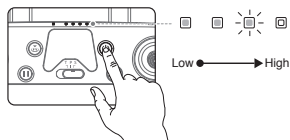

- 💡 Please refer to the user manual for more details about checking the internal and external battery levels.
- ⚠ When using external WB37 Intelligent Battery, it is still necessary to make sure that the internal battery has some power. Otherwise, the Smart Controller cannot be turned on.

## 4. Adjusting the Antennas

Lift the antennas and adjust them. The strength of the Smart Controller signal is affected by the position of the antennas. When the angle between the antennas and the back of the Smart Controller is  $80^\circ$  or  $180^\circ$ , the connection between the Smart Controller and aircraft can reach its optimal performance.

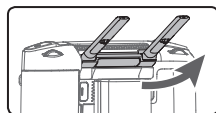

### Optimal Transmission Zone

Try to keep the aircraft inside the optimal transmission zone. If the signal is weak, adjust the antennas or fly the aircraft closer.

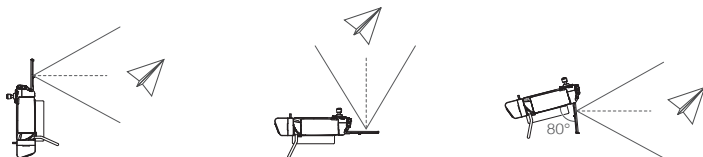

- Avoid using wireless devices that use the same frequency bands as the Smart Controller.
- In real operation, the DJI Pilot app will issue a prompt to warn that the transmission signal is weak, and please adjust the antennas to ensure that the aircraft is back to the optimal transmission range.

## 5. Linking the Smart Controller and Aircraft

When the Smart Controller is purchased together with an aircraft as a combo, it is already linked to the aircraft. If not, please follow the steps below to link the Smart Controller and the aircraft after successful activation.

1. Turn on the Smart Controller and the aircraft.
2. Press down the customizable buttons C1, C2, and the record button simultaneously. The status LED will blink blue and the Smart Controller will sound a double beep to indicate that linking starts.
3. Press and hold the aircraft's power button for at least five seconds to link the aircraft and the Smart Controller. The Smart Controller's status LED will be solid green if linking is successful.



- Please refer to the user manual for more details about linking the Smart Controller to the aircraft. To download the manual, please visit <https://www.dji.com/matrice-300>.

## 6. Flight

Before taking off, make sure the Aircraft Status Bar in the DJI Pilot app displays "Ready to Go (GPS)" or "Ready to Go (RTK)".

Ready to Go (GPS)

## Manual Takeoff/Landing

Combination Stick Command to start/stop the motors.



Slowly push the left stick up to take off. (Mode 2)



Slowly push the left stick down until the aircraft lands. Hold for a few seconds to stop the motors.

The default flight control is known as Mode 2. The left stick controls the aircraft's altitude and heading, while the right stick controls its forward, backward, and left and right movements.

Left Stick

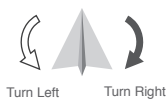
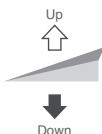

Right Stick



Forward



Backward



Left

Right



- The motors can only be stopped mid-flight when the flight controller detects a critical error. Use with caution.
- Be sure the Smart Controller is linked to the aircraft.
- Refer to the user manual for more Smart Controller usage details (e.g. dual Smart Controller operations).

## Specifications

### • OcuSync Enterprise

Operation Frequency Range 2.400-2.4835 GHz; 5.725-5.850 GHz\*

Max Transmission Distance (Unobstructed, free of interference)  
 2.400-2.4835 GHz:  
 10 km (FCC); 4 km (CE); 4 km (SRRC); 4 km (MIC)  
 5.725-5.850 GHz:  
 8 km (FCC); 2 km (CE); 5 km (SRRC)

Transmitter Power (EIRP)  
 2.400-2.4835 GHz:  
 29.5 dBm (FCC); 18.5 dBm (CE); 18.5 dBm (SRRC); 18.5 dBm (MIC)  
 5.725-5.850 GHz: 28.5 dBm (FCC); 12.5 dBm (CE); 20.5 dBm (SRRC)

### • Wi-Fi

Protocol Wi-Fi Direct, Wi-Fi Display, 802.11a/g/n/ac, Wi-Fi with 2x2 MIMO is supported

Operation Frequency Range 2.400-2.4835 GHz; 5.150-5.250 GHz\*; 5.725-5.850 GHz\*

Transmitter Power (EIRP)	2.400-2.4835 GHz: 20.5 dBm (FCC); 18.5 dBm (CE); 18.5 dBm (SRRC); 20.5 dBm (MIC)
	5.150-5.250 GHz: 14 dBm (FCC); 14 dBm (CE); 14 dBm (SRRC); 14 dBm (MIC)
	5.725-5.850 GHz: 18 dBm (FCC); 12 dBm (CE); 18 dBm (SRRC)

#### • Bluetooth

Protocol	Bluetooth 4.2
Operation Frequency Range	2.400-2.4835 GHz
Transmitter Power (EIRP)	4 dBm (FCC); 4 dBm (CE); 4 dBm (SRRC); 4 dBm (MIC)

#### • General

External Battery	Name: WB37 Intelligent Battery Capacity: 4920 mAh; Voltage: 7.6 V Battery Type: LiPo; Energy: 37.39 Wh Charge Time (Using BS60 Intelligent Battery Station): 70 min (15° to 45° C); 130 min (0° to 15° C)
Built-in Battery	Battery Type: 18650 Li-ion (5000 mAh @ 7.2 V) Charge Type : Supports USB charger rated 12 V / 2 A Rated Power: 17 W** Charge Time: 2 hours and 15 minutes (Using a USB charger rated 12 V / 2 A)
Working Time**	Built-in Battery: Approx. 2.5 hours Built-in Battery + External Battery: Approx. 4.5 hours
Storage Capacity	ROM 32GB + RAM 4GB
Video Output Port	HDMI Port
Power Supply Voltage / Current (USB-A port)	5 V / 1.5 A
Operation Temperature Range	-20° to 40° C (-4° to 104° F)
Storage Temperature Range	Less than one month: -30° to 60° C (-22° to 140° F) One month to three months: -30° to 45° C (-22° to 113° F) Three months to six months: -30° to 35° C (-22° to 95° F) More than six months: -30° to 25° C (-22° to 77° F)
Charging Temperature Range	5° to 40° C (41° to 104° F)
Supported Aircraft Models***	Matrice 300 RTK
GNSS	GPS+GLONASS
Weight	External Battery excluded: Approx. 885 g External Battery included: Approx. 1054 g
Dimensions (Antennas folded)	178×164×108 mm
Model	RM500-ENT

\* Local regulations in some countries prohibit the use of the 5.8 GHz and 5.2 GHz frequencies and in some regions the 5.2 GHz frequency band is only allowed for indoor use.

\*\* The Smart Controller will supply power for the mobile device installed, which may affect the above-mentioned specifications.

\*\*\* The Smart Controller will support more DJI aircraft in future. Please visit the official website for the latest information.



## 免责声明

使用本产品之前，请仔细阅读并遵循本文及大疆™ 创新（DJI™）提供的所有安全指引，并访问 DJI 官方网站（<http://www.dji.com>）下载完整版《用户手册》且仔细阅读其中的所有说明和警告。不遵循或不按照上述文档内容进行操作，或操作过程中不具备强烈的安全注意意识，可能会给您和周围的人带来伤害，损坏本产品或其它周围物品。一旦使用本产品，即视为您已经仔细阅读本免责声明与警告，理解、认可和接受本声明全部条款和内容。您承诺对使用本产品以及可能带来的后果负全部责任，且仅出于正当目的使用本产品。大疆创新（DJI）对于直接或间接使用本产品而造成的损坏、伤害以及任何法律责任不予负责。

DJI 是深圳市大疆创新科技有限公司及其关联公司的商标。本文出现的产品名称、品牌等，均为其所属公司的商标。本产品及手册为大疆创新版权所有。未经许可，不得以任何形式复制翻印。

本文档及本产品所有相关的文档最终解释权归大疆创新（DJI）所有。如有更新，恕不另行通知。请访问 [www.dji.com](http://www.dji.com) 官方网站以获取最新的产品信息。

## 注意事项

使用 DJI 带屏遥控器行业版（以下简称“遥控器”）时，如果操作不当，飞行器可能会对人身财产造成一定程度的伤害和破坏，请在使用时务必注意安全，详情请查看飞行器的免责声明和安全操作指引。请务必于官网下载并阅读详细的用户手册后再进行使用。

1. 每次飞行前，确保遥控器电量充满。
2. 遥控器闲置并熄屏 5 分钟后将发出报警，报警 10 秒后若无操作将自动关机，操作遥控器可让遥控器恢复为正常工作状态。
3. 确保遥控器天线展开并调整到合适的位置，以获得最佳的通信效果。
4. 遥控器天线如有损坏将影响使用性能，请及时联系售后技术支持。
5. 如更换飞行器，需要重新对频才能使用。
6. 确保每次先关闭飞行器电源，再关闭遥控器。
7. 请确保每隔三个月对遥控器进行完全充电一次。
8. 一旦遥控器电量低于 10% 时，务必及时对遥控器进行充电，防止低电量长时间存放导致电池深度过放，导致设备损坏。长期不使用时，请将电池电量放至 40%~60% 左右进行存放。
9. 切勿遮挡遥控器出风口，以免遥控器温度过高，影响遥控器性能。
10. 切勿擅自拆装遥控器，如需更换遥控器部件，请务必联系 DJI 售后 或 DJI 授权的维修中心。
11. 当显示 GPS 信号差时，请检查遥控器内置 GPS 是否受到遮挡。一旦使用屏幕支架，必要时请先移除屏幕支架。
12. 请勿频繁拆装摇杆，避免摇杆防尘罩磨损。

## 简介

DJI 带屏遥控器行业版采用 OCUSYNC™ 行业版高清图传技术，可与支持该图传技术的飞行器搭配使用，并实时传输高清画面。配合遥控器完备的功能按键，可在最大 10 千米通信距离内完成飞行器与相机的操作与设置。\*

遥控器内置 5.5 英寸 1920 × 1080p 高亮触摸屏，最高亮度达 1000 cd/m<sup>2</sup>，兼容其它移动设备以提升使用灵活性。采用 Android 系统，具备蓝牙及卫星定位等功能。支持通过 Wi-Fi 或 4G 无线上网卡的方式连接至互联网。

遥控器内置电池满电时工作时间约 2.5 小时；外接 WB37 智能电池与内置电池均满电时，则工作时间约 4.5 小时。\*\*

\* 在开阔无遮挡、无电磁干扰的环境飞行，并且飞行高度为 120 米左右，在 FCC 标准下遥控器可以达到最大通信距离。由于实际飞行环境中存在的干扰，最大通信距离可能小于此标称距离，且会随干扰强度发生变化。部分国家不支持 5.8 GHz 频段，以遵从当地法规。

\*\* 上述可工作时间为实验室环境下测得，不同使用场景的续航时间不同，仅供参考。

## 物品清单

遥控器

× 1

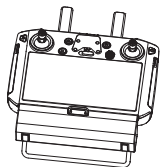

WB37 智能电池

× 1

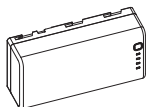

USB 充电器 \*\*\*

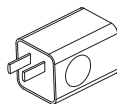

USB-C 线

× 1



双 A 口 USB 线

× 1



遥控器挂带

× 1



备用摇杆（对）

× 1



备用摇杆防尘罩（对）

× 1



文档



遥控器使用说明

WB37 智能电池安全使用指引

\*\*\* 实物及其数量根据地区有所不同。

## 部件介绍

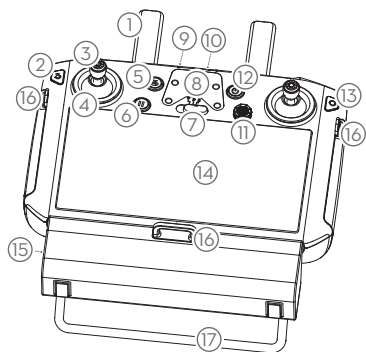

1. 天线
2. 退回按键 / 系统功能按键
3. 摇杆
4. 摇杆防尘罩
5. 智能返航按键
6. 急停按键
7. 飞行模式切换开关
8. 支架安装位置 (正下方内置 GPS)
9. 状态指示灯
10. 电量指示灯
11. 五维按键
12. 电源按键
13. 确认按键 / 自定义功能按键 C3
14. 触摸显示屏
15. 充电接口 (USB-C)
16. 背带挂钩
17. 提手

18. 云台俯仰控制拨轮
19. 录影按键
20. HDMI 接口
21. microSD 卡槽
22. USB-A 接口
23. 对焦 / 拍照按键
24. 云台水平控制拨轮

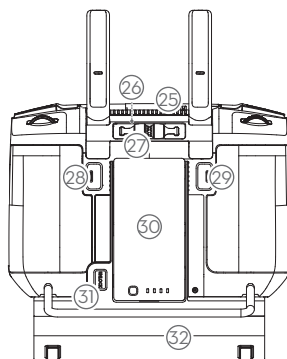
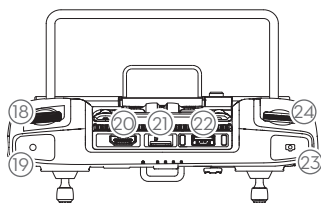

25. 出风口
26. 摇杆收纳槽
27. 备用摇杆
28. 自定义功能按键 C2
29. 自定义功能按键 C1
30. WB37 智能电池
31. 电池解锁按钮
32. 无线上网卡仓盖

## 1. 充电

使用官方 USB 充电器，完全充满需要约 2 小时 15 分钟。

交流电源  
100-240 V      USB 充电器      USB-C 线

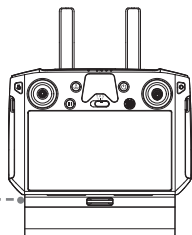

- 请使用官方充电器对遥控器进行充电。如不使用官方充电器，推荐使用符合 FCC / CE 标准，规格为 12 V / 2 A 的 USB 充电器。
- 为保持遥控器电池最佳状态，请确保每 3 个月对遥控器进行完全充电一次。

## 2. 安装智能电池

- ① 按住遥控器背面的电池解锁按钮。
- ② 将智能电池装入电池仓，使电池底部与仓内标识线对齐。
- ③ 将电池向下推到底。

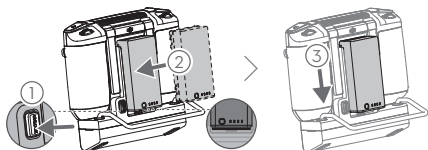

- 如需取下智能电池，按住电池解锁按钮，然后向上推动智能电池将其取出。
- 请使用 BS60 智能电池箱进行充电，具体请阅读《BS60 智能电池箱使用说明》。

## 3. 安装无线上网卡及 SIM 卡



- 务必使用 DJI 指定的无线上网卡。
- 无线上网卡配合 SIM 卡使用，可为遥控器提供 LTE 增强链路或提供网络连接（例如连接网络 RTK 服务器），务必确保将其正确安装至遥控器内部，否则将无法使用相关服务。
- 无线上网卡及 SIM 卡需另行购买。

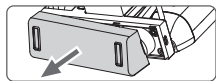

移除遥控器无线上网卡仓盖。

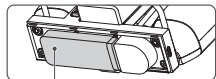

无线上网卡

无线上网卡中装入 SIM 卡，然后将无线上网卡接入仓内部的 USB 接口。测试确保工作正常\*。

\* 测试方法：确保遥控器和飞行器都插上上网卡，开启两者电源，进入 DJI Pilot App > HD > LTE 增强链路，查看 4G 上下行链路状态，信号正常则表示无线上网卡及 SIM 卡可正常使用。

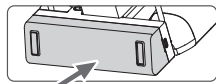

重新安装上网卡仓盖，确保安装稳固。

## 4. 检查电量 / 开启遥控器

使用电量指示灯查看内置电池电量（关机时可短按一次电源按键进行查看）。

短按再长按电源按键可开启 / 关闭遥控器电源。

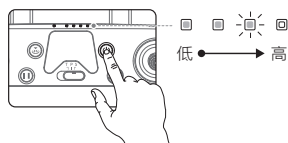

• 更多检查内置电池和外置电池电量的内容，请查看详细的用户手册。



• 使用外置电池时，仍需确保内置电池具有一定的电量，否则遥控器将无法开机。

## 5. 调整天线

展开遥控器天线并调整天线位置，不同的天线位置接收到的信号强度不同。当天线与遥控器背面呈  $80^\circ$  或  $180^\circ$  夹角，且天线平面正对飞行器时，可让遥控器与飞行器的信号质量达到最佳状态。

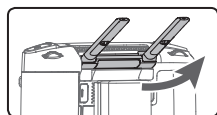

### 最佳通信范围

操控飞行器时，务必使飞行器处于最佳通信范围内。及时调整操控者与飞行器之间的方位或距离，以确保飞行器总是位于最佳通信范围内。

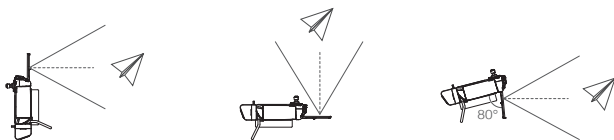

• 请勿同时使用其它同频段的通信设备，以免对遥控器信号造成干扰。

• 实际操作中，DJI Pilot App 在图传信号不佳时将会进行提示，请根据提示调整天线位置，确保飞行器处于最佳通信范围。

## 6. 对频

遥控器与飞行器呈套装形式购买时，出厂时已与飞行器进行对频，开机激活后可直接使用。其它情况下，请使用以下方法进行对频。

1. 开启遥控器和飞行器电源。
2. 同时按下遥控器自定义按键 C1、C2 和录影按键，此时遥控器状态指示灯显示蓝灯闪烁，并发出“滴滴”提示音进入对频状态。
3. 长按飞行器电源按键 5 秒及以上可以进行飞行器与遥控器对频，等待几秒钟后完成对频。对频成功后，遥控器状态指示灯将会呈绿灯常亮。



• 更多对频方式，请查看详细的用户手册。下载地址：<https://www.dji.com/cn/matrice-300>

## 7. 飞行

起飞前请务必等待显示屏相机界面显示“起飞准备完毕 (GPS)”或“起飞准备完毕 (RTK)”。

起飞准备完毕 (GPS)

### 手动起飞 / 降落

掰杆动作  
电机启动 / 停止



**起飞**  
缓慢向上推动油门杆  
(默认左摇杆) 飞行器起飞



**降落**  
向下拉油门杆至飞行器落地，在最低位置保持 2 秒，电机停止。

遥控器出厂默认操控方式为“美国手”。飞行过程中，可使用左摇杆控制飞行高度与方向，右摇杆控制飞行器的前进、后退以及左右飞行方向。

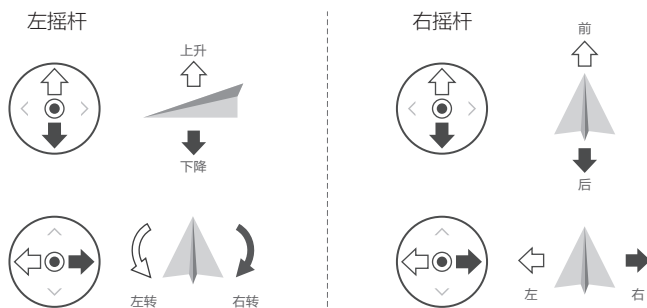

- 如飞行器在空中检测到严重故障，才可执行紧急停桨的操作。
- 请确保遥控器已成功与飞行器对频。
- 遥控器的更多功能（如双遥控器功能），详细请阅读用户手册。

## 规格参数

### • OcuSync 行业版

工作频率	2.400-2.4835 GHz; 5.725-5.850 GHz*
最大信号有效距离 (无干扰、无遮挡)	2.400-2.4835 GHz: 10 km (FCC); 4 km (CE); 4 km (SRRC); 4 km (MIC) 5.725-5.850 GHz: 8 km (FCC); 2 km (CE); 5 km (SRRC)

等效全向辐射功率 (EIRP)	2.400-2.4835 GHz: 29.5 dBm (FCC) ; 18.5 dBm (CE) ; 18.5 dBm (SRRC) ; 18.5 dBm (MIC) 5.725-5.850 GHz: 28.5 dBm (FCC) ; 12.5 dBm (CE) ; 20.5 dBm (SRRC)
<b>• Wi-Fi</b>	
协议	Wi-Fi Direct, Wi-Fi Display, 802.11a/g/n/ac 支持 2 x 2 MIMO Wi-Fi
工作频率	2.400-2.4835 GHz; 5.150-5.250 GHz*; 5.725-5.850 GHz*
等效全向辐射功率 (EIRP)	2.400-2.4835 GHz: 20.5 dBm (FCC) ; 18.5 dBm (CE) ; 18.5 dBm (SRRC) ; 20.5 dBm (MIC) 5.150-5.250 GHz: 14 dBm (FCC) ; 14 dBm (CE) ; 14 dBm (SRRC) ; 14 dBm (MIC) 5.725-5.850 GHz: 18 dBm (FCC) ; 12 dBm (CE) ; 18 dBm (SRRC)
<b>• 蓝牙</b>	
协议	蓝牙 4.2
工作频率	2.400-2.4835 GHz
等效全向辐射功率 (EIRP)	4 dBm (FCC) ; 4 dBm (CE) ; 4 dBm (SRRC) ; 4 dBm (MIC)
<b>• 其它参数</b>	
外置电池	名称: WB37 智能电池 容量: 4920 mAh 电压: 7.6 V 电池类型: LiPo 能量: 37.39 Wh 充电时间 (使用 BS60 智能电池箱): 70 分钟 (15°C 至 45°C) ; 130 分钟 (0°C 至 15°C)
内置电池	类型: 18650 锂离子电池 (5000 mAh @ 7.2 V) 充电方式: 使用规格为 12 V / 2 A 的 USB 充电器 额定功耗: 17 W** 充电时间: 2 小时 15 分钟 (使用规格为 12 V / 2 A 的 USB 充电器)
续航时间 **	内置电池: 约 2.5 小时 内置电池 + 外置电池: 约 4.5 小时
存储空间	ROM 32GB + RAM 4GB
视频输出接口	HDMI 接口
USB-A 接口供电电压 / 电流	5 V / 1.5 A
工作环境温度	-20°C 至 40°C
存放环境温度	-30°C 至 60°C (一个月内) -30°C 至 45°C (大于一个月小于三个月) -30°C 至 35°C (大于三个月小于六个月) -30°C 至 25°C (大于六个月)
充电环境温度	5°C 至 40°C
支持的 DJI 飞行器 ***	Matrice 300 RTK
GNSS	GPS+GLONASS 双模
重量	不含外置电池: 约 885 g 含外置电池: 约 1054 g
尺寸 (天线折叠)	178 × 164 × 108 mm
型号	RM500-ENT

\* 部分地区不支持 5.2 GHz 和 5.8GHz 频段, 以及部分地区 5.2 GHz 频段仅限室内使用, 详情请参考当地法律法规。

\*\* 安装其它移动设备时, 则遥控器对外供电时参数会有变化。

\*\*\* 后续将会支持更多 DJI 飞行器, 请留意官网获取最新信息。